



Renegade

ES 300i

Welding power source Stick 300 A

RENEGADE™

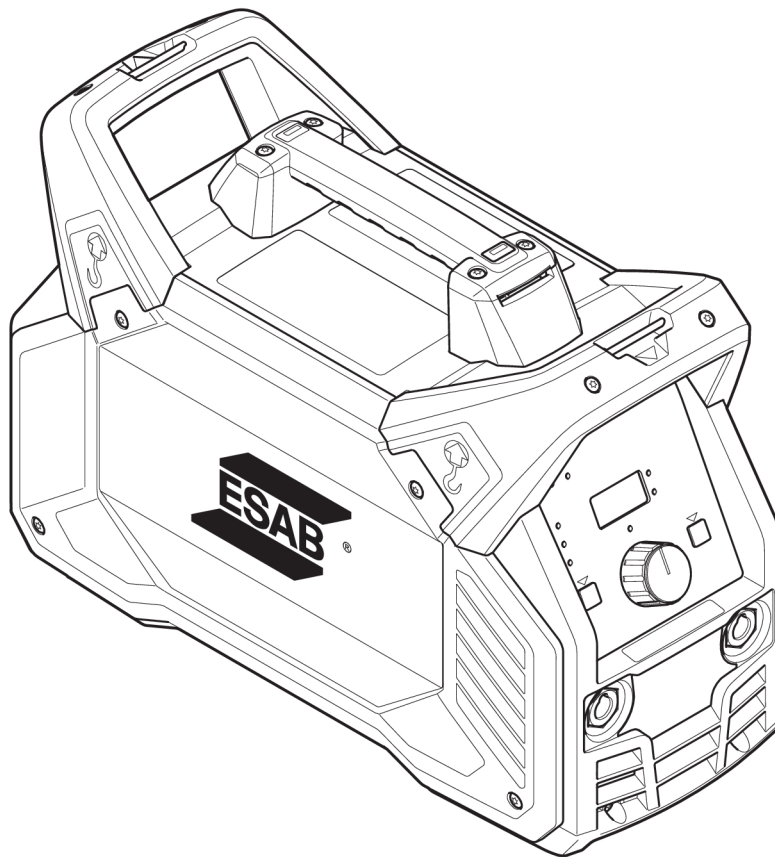

Instruction manual

1	SAFETY	3
1.1	Meaning of symbols	3
1.2	Safety precautions	3
1.3	User responsibility	7
2	INTRODUCTION	10
2.1	Overview	10
2.2	Equipment	10
3	TECHNICAL DATA	11
4	INSTALLATION	13
4.1	Location	13
4.2	Lifting instructions	13
4.3	Main supply	14
5	OPERATION	19
5.1	Overview	19
5.2	Connections and control devices	19
5.3	Connecting welding and return cables	20
5.4	Turning the power on/off	20
5.5	Fan control	20
5.6	Thermal protection	20
5.7	Functions and symbols	20
5.8	Setting panel	22
5.8.1	Navigation	22
5.9	Remote control	23
5.10	USB connection	23
5.11	Low energy idle state	23
6	MAINTENANCE	24
6.1	Routine maintenance	24
6.2	Cleaning instructions	24
7	TROUBLESHOOTING	28
8	ERROR CODES	29
8.1	Error code descriptions	29
9	ORDERING SPARE PARTS	30
	DIAGRAM	31
	ORDERING NUMBERS	32
	ACCESSORIES	33

1 SAFETY

1.1 Meaning of symbols

As used throughout this manual: Means Attention! Be Alert!



DANGER!

Means immediate hazards which, if not avoided, will result in immediate, serious personal injury or loss of life.



WARNING!

Means potential hazards which could result in personal injury or loss of life.



CAUTION!

Means hazards which could result in minor personal injury.



WARNING!

Before use, read and understand the instruction manual and follow all labels, employer's safety practices and Safety Data Sheets (SDSs).



1.2 Safety precautions



WARNING!

These Safety Precautions are for your protection. They summarize precautionary information from the references listed in the Additional Safety Information section. Before performing any installation or operating procedures, be sure to read and follow the safety precautions listed below as well as all other manuals, material safety data sheets, labels, etc. Failure to observe Safety Precautions can result in injury or death.



PROTECT YOURSELF AND OTHERS

Some welding, cutting and gouging processes are noisy and require hearing protection. The arc, like the sun, emits ultraviolet (UV) and other radiation and can injure the skin and eyes. Hot metal can cause burns. Training in the proper use of the processes and equipment is essential to prevent accidents. Therefore:

1. Wear a welding helmet fitted with a proper shade of filter to protect your face and eyes when welding or watching.
2. Always wear safety glasses with side shields in any work area, even if welding helmets, face shields and goggles are also required.
3. Use a face shield fitted with the correct filter and cover plates to protect your eyes, face, neck and ears from sparks and rays of the arc when operating or observing operations. Warn bystanders not to look at the arc and not to expose themselves to the rays of the electric-arc or hot metal.
4. Wear flameproof gauntlet-type gloves, heavy long-sleeve shirt, cuffless pants, high-topped shoes, and a welding helmet or cap for protection, to protect against arc rays and hot sparks or hot metal. A flameproof apron may also be desirable as protection against radiated heat and sparks.

5. Hot sparks or metal can lodge in rolled up sleeves, trouser cuffs, or pockets. Sleeves and collars should be kept buttoned and open pockets eliminated from the front of the clothing.
6. Protect other personnel from arc rays and hot sparks with a suitable non-flammable partition or curtains.
7. Use goggles over safety glasses when chipping slag or grinding. Chipped slag may be hot and can fly for long distances. Bystanders should also wear goggles over safety glasses.



FIRES AND EXPLOSIONS

The heat from flames and arcs can start fires. Hot slag or sparks can also cause fires and explosions. Therefore:

1. Protect yourself and others from flying sparks and hot metal.
2. Move all combustible materials well away from the work area or cover the materials with a protective non-flammable covering. Combustible materials include wood, cloth, sawdust, liquid and gas fuels, solvents, paints, and coating paper, etc.
3. Hot sparks or hot metal can fall through cracks or crevices in floors or wall openings and cause a hidden smoldering fire or fires on the floor below. Make certain that such openings are protected from hot sparks and metal.
4. Do not weld, cut, or perform other hot work until the work piece has been completely cleaned so that there are no substances on the work piece which might produce flammable or toxic vapors. Do not perform hot work on closed containers, they may explode.
5. Have fire extinguishing equipment handy for instant use, such as a garden hose, water pail, sand bucket, or portable fire extinguisher. Be sure you are trained in its use.
6. Do not use equipment beyond its ratings. For example, an overloaded welding cable can overheat and create a fire hazard.
7. After completing work, inspect the work area to make sure there are no hot sparks or hot metal that could cause a fire later. Use fire watchers when necessary.



ELECTRICAL SHOCK

Contact between live electrical parts and earth can cause severe injury or death. DO NOT use AC welding current in damp areas, if movement is confined, or if there is danger of falling. Therefore:

1. Be sure the power source frame (chassis) is connected to the earth system of the input power.
2. Connect the workpiece to a good electrical earth.
3. Connect the work cable to the workpiece. A poor or missing connection can expose you or others to a fatal shock.
4. Use well-maintained equipment. Replace worn or damaged cables.
5. Keep everything dry, including clothing, work area, cables, torch/electrode holder and power source.
6. Make sure that all parts of your body are insulated from both the work piece and from the ground.
7. Do not stand directly on metal or the ground while working in tight quarters or a damp area; stand on dry boards or an insulating platform and wear rubber-soled shoes.
8. Put on dry, hole-free gloves before turning on the power.
9. Turn off the power, before removing your gloves.
10. Refer to ANSI/ASC Standard Z49.1 for specific grounding recommendations. Do not mistake the work lead for a earth cable.



ELECTRIC AND MAGNETIC FIELDS

May be dangerous. Electric current flowing through any conductor causes localized Electric and Magnetic Fields (EMF). Welding and cutting current creates EMF around welding cables and welding machines. Therefore:

1. Welders having pacemakers should consult their physician before welding. EMF may interfere with some pacemakers.
2. Exposure to EMF may have other health effects which are unknown.
3. Welders should use the following procedures to minimise exposure to EMF:
 - a) Route the electrode and work cables together. Secure them with tape when possible.
 - b) Never coil the torch or work cable around your body.
 - c) Do not place your body between the torch and work cables. Route cables on the same side of your body.
 - d) Connect the work cable to the workpiece as close as possible to the area being welded.
 - e) Keep welding power source and cables as far away from your body as possible.



FUMES AND GASES

Fumes and gases, can cause discomfort or harm, particularly in confined spaces. Shielding gases can cause asphyxiation. Therefore:

1. Keep your head out of the fumes. Do not breathe the fumes and gases.
2. Always provide adequate ventilation in the work area by natural or mechanical means. Do not weld, cut or gouge on materials such as galvanized steel, stainless steel, copper, zinc, lead beryllium or cadmium unless positive mechanical ventilation is provided. Do not breathe in the fumes from these materials.
3. Do not operate near degreasing and spraying operations. The heat or arc can react with chlorinated hydrocarbon vapors to form phosgene, a highly toxic gas, and other irritant gases.
4. If you develop momentary eye, nose or throat irritation while operating, this is an indication that the ventilation is not adequate. Stop work and take the necessary steps to improve ventilation in the work area. Do not continue to operate if physical discomfort persists.
5. Refer to ANSI/ASC Standard Z49.1 for specific ventilation recommendations.
6. **WARNING:** This product when used for welding or cutting, produces fumes or gases that contain chemicals known to the State of California to cause birth defects and in some cases cancer (California Health & Safety Code §25249.5 et seq.)



CYLINDER HANDLING

Cylinders, if mishandled, can rupture and violently release gas. A sudden rupture of cylinder valve or relief device can injure or kill. Therefore:

1. Locate cylinders away from heat, sparks and flames. Never strike an arc on a cylinder.
2. Use the proper gas for the process and use the proper pressure reducing regulator designed to operate from the compressed gas cylinder. Do not use adapters. Maintain hoses and fittings in good condition. Follow the manufacturer's operating instructions for mounting a regulator to a compressed gas cylinder.

3. Always secure cylinders in an upright position, by chain or strap, to suitable hand trucks, undercarriages, benches, wall, post or racks. Never secure cylinders to work tables or fixtures where they may become part of an electrical circuit.
4. When not in use, keep cylinder valves closed. Have valve protection cap in place if regulator is not connected. Secure and move cylinders by using suitable hand trucks.



MOVING PARTS

Moving parts, such as fans, rotors and belts can cause injury. Therefore:

1. Keep all doors, panels, guards, and covers closed and securely in place.
2. Stop the engine or drive systems before installing or connecting a unit.
3. Have only qualified people remove covers for maintenance and troubleshooting as necessary
4. To prevent accidental starting of equipment during service, disconnect negative (-) battery cable from battery.
5. Keep hands, hair, loose clothing and tools away from moving parts.
6. Reinstall panels or covers and close doors when service is finished and before starting engine.



WARNING!

FALLING EQUIPMENT CAN INJURE

- Only use lifting eye to lift unit. Do NOT use running gear, gas cylinders or any other accessories.
- Use equipment of adequate capacity to lift and support unit.
- If using lift forks to move unit, be sure forks are long enough to extend beyond opposite side of unit.
- Keep cables and cords away from moving vehicles when working from an aerial location.



WARNING!

EQUIPMENT MAINTENANCE

Faulty or improperly maintained equipment can cause injury or death.

Therefore:

1. Always have qualified personnel perform the installation, troubleshooting and maintenance work. Do not perform any electrical work unless you are qualified to perform such work.
2. Before performing any maintenance work inside a power source, disconnect the power source from the incoming electrical power.
3. Maintain cables, earthing wire, connections, power cord and power supply in safe working order. Do not operate any equipment in faulty condition.
4. Do not abuse any equipment or accessories. Keep equipment away from heat sources such as furnaces, wet conditions such as water puddles, oil or grease, corrosive atmospheres and inclement weather.
5. Keep all safety devices and cabinet covers in position and in good repair.
6. Use equipment only for its intended purpose. Do not modify it in any manner.

**CAUTION!****ADDITIONAL SAFETY INFORMATION**

For more information on safe practices for electric arc welding and cutting equipment, ask your supplier for a copy of “Precautions and Safe Practices for Arc Welding, Cutting and Gouging,” Form 52-529.

The following publications are recommended:

- ANSI/ASC Z49.1 - “Safety in Welding and Cutting”
- AWS C5.5 - “Recommended Practices for Gas Tungsten Arc Welding”
- AWS C5.6 - “Recommended Practices for Gas Metal Arc welding”
- AWS SP - “Safe practices” - Reprint, Welding Handbook
- ANSI/AWS F4.1 - “Recommended Safe Practices for Welding and Cutting of Containers That Have Held Hazardous Substances”
- OSHA 29 CFR 1910 - "Safety and health standards"
- CSA W117.2 - "Code for safety in welding and cutting"
- NFPA Standard 51B, “Fire Prevention During Welding, Cutting, and Other Hot Work”
- CGA Standard P-1, “Precautions for Safe Handling of Compressed Gases in Cylinders”
- ANSI Z87.1, "Occupational and Educational Personal Eye and Face Protection Devices"

1.3 User responsibility

Users of ESAB equipment have the ultimate responsibility for ensuring that anyone who works on or near the equipment observes all the relevant safety precautions. Safety precautions must meet the requirements that apply to this type of equipment. The following recommendations should be observed, in addition to the standard regulations that apply to the workplace.

All work must be carried out by trained personnel well-acquainted with the operation of the equipment. Incorrect operation of the equipment may lead to hazardous situations, which could result in injury to the operator and damage to the equipment.

1. Anyone who uses the equipment must be familiar with:
 - its operation
 - the location of emergency stops
 - its function
 - the relevant safety precautions
 - welding and cutting or other applicable operation of the equipment
2. The operator must ensure that:
 - no unauthorized person is within the working area of the equipment when it is started up
 - no-one is unprotected when the arc is struck or work is started with the equipment
3. The workplace must:
 - be suitable for the purpose
 - be free from drafts

4. Personal safety equipment:
 - Always wear recommended personal safety equipment, such as safety glasses, flame-proof clothing, safety gloves
 - Do not wear loose-fitting items, such as scarves, bracelets, rings, etc., which could become trapped or cause burns
5. General precautions:
 - Make sure the return cable is connected securely
 - Work on high voltage equipment **may only be carried out by a qualified electrician**
 - Appropriate fire extinguishing equipment must be clearly marked and close at hand
 - Lubrication and maintenance must **not** be carried out on the equipment during operation

**WARNING!**

Arc welding and cutting may cause injury to yourself and others. Take precautions when welding and cutting.

**ELECTRIC SHOCK - Can kill**

- Install and ground the unit in accordance with instruction manual.
- Do not touch live electrical parts or electrodes with bare skin, wet gloves, or wet clothing.
- Insulate yourself from work and ground.
- Ensure your working position is safe

**ELECTRIC AND MAGNETIC FIELDS - Pose health risks**

- Welders with pacemakers fitted should consult their doctor before welding. EMF may interfere with some pacemakers.
- Exposure to EMF may have other health effects which are unknown.
- Welders should use the following procedures to minimize exposure to EMF:
 - Route the electrode and work cables together on the same side of your body. Secure them with tape when possible. Do not place your body between the torch and work cables. Never coil the torch or work cable around your body. Keep the welding power source and cables as far away from your body as possible.
 - Connect the work cable to the workpiece as close as possible to the area being welded.

**FUMES AND GASES - Can be dangerous to your health**

- Keep your head out of the fumes.
- Use ventilation, extraction at the arc, or both, to take fumes and gases away from your breathing zone and the general area.

**ARC RAYS - Can injure eyes and burn skin**

- Protect your eyes and body. Use the correct welding screen and filter lens and wear protective clothing.
- Protect bystanders with suitable screens or curtains.

**NOISE - Excessive noise can damage hearing**

Protect your ears. Use ear defenders or other hearing protection.

MOVING PARTS - Can cause injuries



- Keep all doors, panels and covers closed and securely in place. Have only qualified people remove covers for maintenance and troubleshooting as necessary. Reinstall panels or covers and close doors when service is finished and before starting engine.



- Stop engine before installing or connecting unit.
- Keep hands, hair, loose clothing and tools away from moving parts.

FIRE HAZARD



- Sparks (spatter) can cause a fire. Make sure there are no inflammable materials nearby.
- Do not use on closed containers.

MALFUNCTION - Call for expert assistance in the event of malfunction.

PROTECT YOURSELF AND OTHERS!



WARNING!

Do not use the power source for thawing frozen pipes.



CAUTION!

This product is solely intended for arc welding.

ESAB has an assortment of welding accessories and personal protection equipment for purchase. For ordering information, contact your local ESAB dealer or visit us on our website.

2 INTRODUCTION

2.1 Overview

The **ES 300i** is an inverter-based power source intended for coated electrode (stick) and tungsten inert gas (GTAW) welding.

ESAB accessories for the product can be found in the "ACCESSORIES" chapter of this manual.

2.2 Equipment

The power source is supplied with:

- 9.8 ft (3 m) mains cable without plug
- 2 × OKC 50 male contact - only for ES 300i with ordering no. 0445 100 881
- Instruction manual
- Quick start guide

3 TECHNICAL DATA

ES 300i		
Mains voltage	220–480 V ± 10%, 3~ 50/60 Hz	220 V±10%, 1~ 50/60 Hz
Primary current		
I _{max} Stick (SMAW)	32.0 A	29.0 A
I _{max} GTAW (TIG)	21.0 A	20.0 A
No-load power demand when in energy-saving mode	91 W ¹⁾ , 27 W ³⁾	91 W ¹⁾ , 74 W ²⁾ 20 W ³⁾
Setting range		
Stick (SMAW)	5 A / 20 V - 300 A / 32 V	5 A / 20 V - 200 A / 28 V
GTAW (TIG)	5 A / 10 V - 300 A / 22 V	5 A / 10 V - 200 A / 18 V
Permissible load at Stick (SMAW)		
40% duty cycle	300 A / 32.0 V	
60% duty cycle	250 A / 30.0 V	
100% duty cycle	200 A / 28.0 V	200 A / 28.0 V
Permissible load at GTAW (TIG)		
60% duty cycle	300 A / 22.0 V	
100% duty cycle	250 A / 20.0 V	200 A / 18.0 V
Apparent power I₂ at maximum current	11.3 kVA	6.6 kVA
Active power I₂ at maximum current	10.8 kW	6.5 kW
Power factor at maximum current		
GTAW (TIG)	0.96	0.96 ¹⁾ , 0.98 ²⁾
Stick (SMAW)	0.96	0.96 ¹⁾ , 0.99 ²⁾
Efficiency at maximum current		
Stick (SMAW)	89%	89% ¹⁾ , 87% ²⁾
GTAW (TIG)	85%	85% ¹⁾ , 84% ²⁾
Open-circuit voltage U₀ max		
VRD 35 V deactivated	48 V	48 V
VRD 35 V activated	32 V ¹⁾ , 34 V ²⁾	32 V ¹⁾ , 34 V ²⁾
Operating temperature	+14 to +104 °F (-10 to +40 °C)	+14 to +104 °F (-10 to +40 °C)
Transportation temperature	-4 to +131 °F (-20 to +55 °C)	-4 to +131 °F (-20 to +55 °C)
Continual sound pressure at no-load	<70 db (A)	<70 db (A)
Dimensions l × w × h	18.1x7.9x12.6 in. (460×200×320 mm)	18.1×7.9×12.6 in. (460×200×320 mm)
Weight	33 lb (15 kg)	33 lb (15 kg)
Insulation class transformer	F	F

ES 300i		
Enclosure class	IP23	IP23
Application class	S	S

- 1) Serial number 627-xxx-xxxx to 643-xxx-xxxx
- 2) From serial number 719-xxx-xxxx
- 3) From serial number 239-xxx-xxxx

Duty cycle

The duty cycle refers to the time as a percentage of a ten-minute period that you can weld or cut at a certain load without overloading. The duty cycle is valid for 104 °F (40 °C) or below.

Enclosure class

The **IP** code indicates the enclosure class, i.e. the degree of protection against penetration by solid objects or water.

Equipment marked **IP23** is intended for indoor and outdoor use.

Application class

The symbol **S** indicates that the power source is designed for use in areas with increased electrical hazard.

4 INSTALLATION

The installation must be carried out by a professional.



CAUTION!

This product is intended for industrial use. In a domestic environment, this product may cause radio interference. It is the user's responsibility to take adequate precautions.

4.1 Location

Position the power source so that its cooling air inlets and outlets are not obstructed.

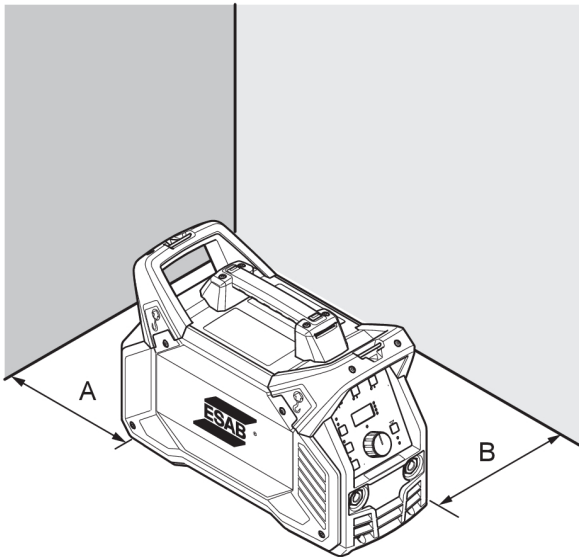

A. Minimum 200 mm (8")

B. Minimum 200 mm (8")



WARNING!

Secure the equipment - particularly if the ground is uneven or sloping.

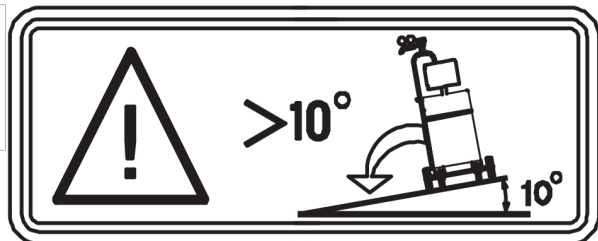

4.2 Lifting instructions

Mechanical lifting must be done with both outer handles.

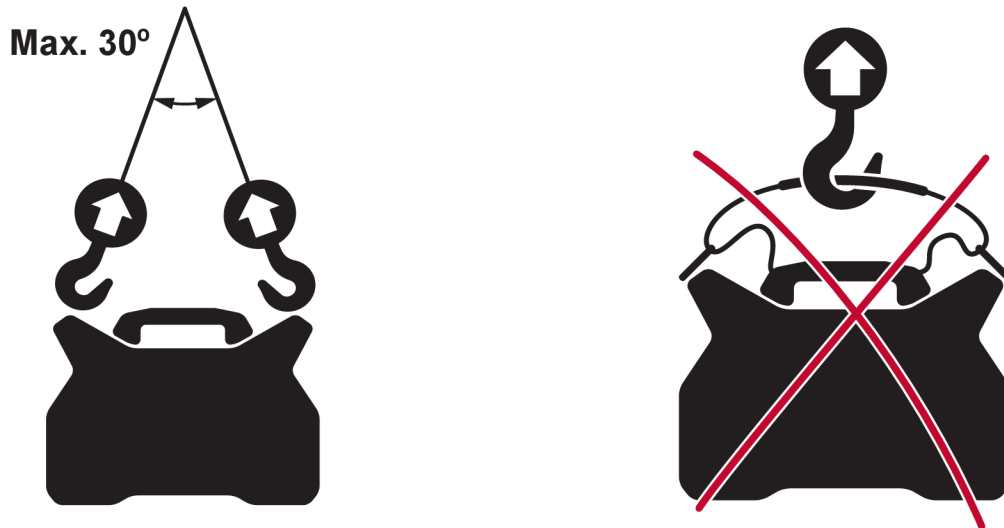

4.3 Main supply

The power source will automatically adjust to the supplied input voltage. Make sure that it is protected by the correct fuse rating. A protective ground connection must be made, in accordance with regulations.

Rating plate with supply connection data

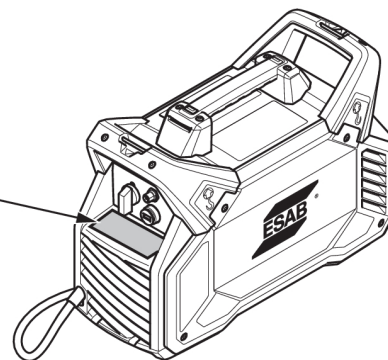

Recommended fuse sizes and minimum cable area ES300i							
Mains voltage	220 V 3~ 50/60 Hz	380 V 3~ 50/60 Hz	400 V 3~ 50/60 Hz	440 V 3~ 50/60 Hz	480 V 3~ 50/60 Hz	220 V 1~ 60 Hz	230 V 1~ 60 Hz
Mains cable area	4×4 mm ² / 4×12 AWG	4×2.5 m m ² / 4×15 AWG	4×2.5 m m ² / 4×16 AWG	4×2.5 m m ² / 4×16 AWG	4×2.5 m m ² / 4×16 AWG	3×6 mm ² / 3×10 AWG	3×6 mm ² / 3×10 AWG
Maximal current rating I_{max} SMAW/Stick (MMA)	30.2 A	17.0 A	16.0 A	16.0 A	14.0 A	29.0 A	28.0 A
I_{1eff} SMAW/Stick (MMA)	18.5 A	11.0 A	10.0 A	10.0 A	9.0 A	29.0 A	28.0 A

Recommended fuse sizes and minimum cable area ES300i							
Mains voltage	220 V 3~ 50/60 Hz	380 V 3~ 50/60 Hz	400 V 3~ 50/60 Hz	440 V 3~ 50/60 Hz	480 V 3~ 50/60 Hz	220 V 1~ 60 Hz	230 V 1~ 60 Hz
Fuse anti-surge	20 A	16 A	10 A	10 A	10 A	35 A	35 A
type C MCB	20 A	16 A	16 A	10 A	10 A	35 A	35 A
Maximum recommended extension cord length	100 m / 330 ft	100 m / 330 ft	100 m / 330 ft	100 m / 330 ft	100 m / 330 ft	100 m / 330 ft	100 m / 330 ft
Minimum recommended extension cord size	4×4 mm ² / 4×12 AWG	4×4 mm ² / 4×12 AWG	4×4 mm ² / 4×12 AWG	4×4 mm ² / 4×12 AWG	4×4 mm ² / 4×12 AWG	3×6 mm ² / 3×10 AWG	3×6 mm ² / 3×10 AWG

**NOTE!**

Different variants of ES 300i are certified for different outlet voltages. Always refer to the rating plate for the specification of the power source in use.

**NOTE!**

The power cable areas and fuse sizes as shown above are in accordance with Swedish regulations. Use the power source in accordance with the relevant national regulations.

Supply from power generators

The power source can be supplied from different types of generators. However, some generators may not provide sufficient power for the welding power source to operate correctly. Generators with Automatic Voltage Regulation (AVR) or with equivalent or better type of regulation, with 20 kW rated power, are recommended.

Installation of electrical cable

**NOTE!**

The power source is delivered with a 4×12 AWG mains cable which can handle the rated data given for 3-phase 220–480 V mains supply. If other outlet voltages are required, the power cable can be changed in accordance with local regulations. For recommendations, see section Recommended fuse sizes and minimum cable area.

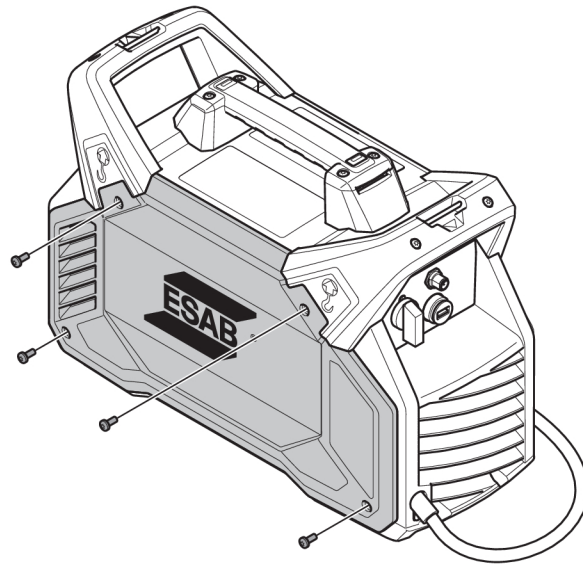

1. Remove the side panel.
2. If tightened, release the stopping block **(A)**.
3. If a cable is connected, disconnect all wires, cut the cable tie **(C)**, and remove the cable.
4. Optional: The fan with foam can now be removed to simplify installation. Note the direction of the fan (sticker toward the inside).
5. Strip the new wire in accordance with specifications **(B)**.
6. Insert the cable with about 0.4 in. (1 cm) of isolation inside the stopping block. Tighten the stopping block by using 13.3–17.7 in. lb (1.5-2 Nm) **(A)**.
7. Use two cable ties to fasten the cables **(C)**.
8. Optional: If the fan with foam was removed, it must now be reinstalled. A symbol on the side of the fan **(G)** shows the airflow direction.
9. Connect the earth wire **(H)**. A toothed washer should be located closest to the heat sink. Tighten the screw to a torque of 53.1 ± 5.3 in. lb (6.0 ± 0.6 Nm).
10. Connect all wires in accordance with illustrations for 1-phase and 3-phase. L3 will only be used for 3-phase **(D)**. Tighten the screw to a torque of 8.9 ± 1.8 in. lb (1.0 ± 0.2 Nm).
11. Make sure that the IP shield is correctly mounted on the inside of the side panel **(E)**.
12. Reassemble the side panel **(F)**.
13. Tighten the screws on the side panel with 26.6 ± 2.7 in. lb (3 ± 0.3 Nm).

3-phase

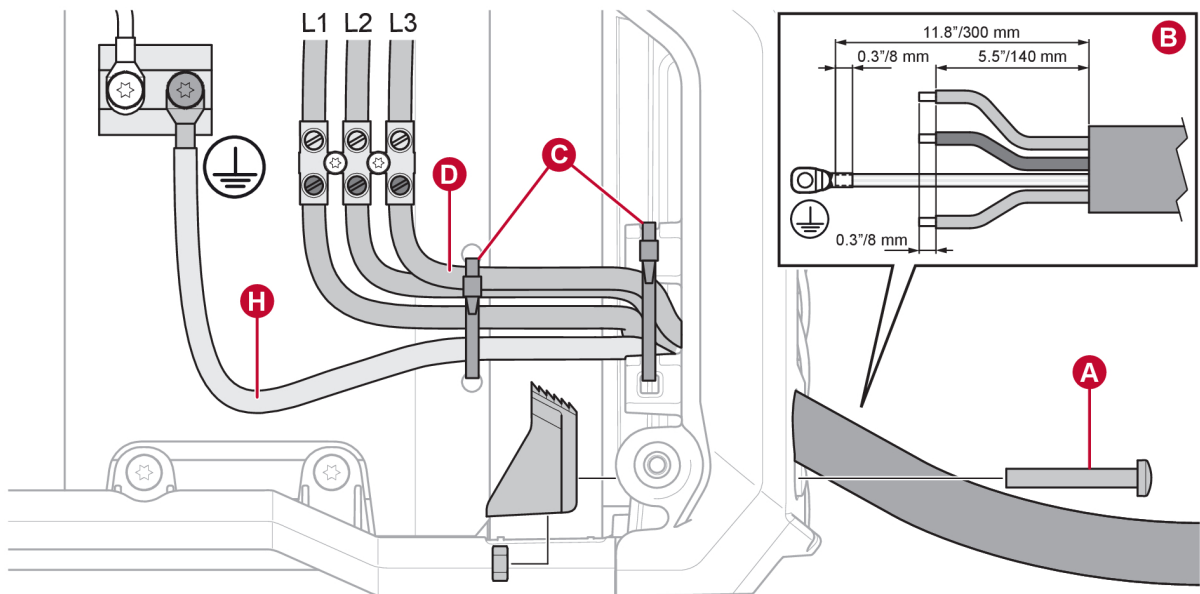

1-phase

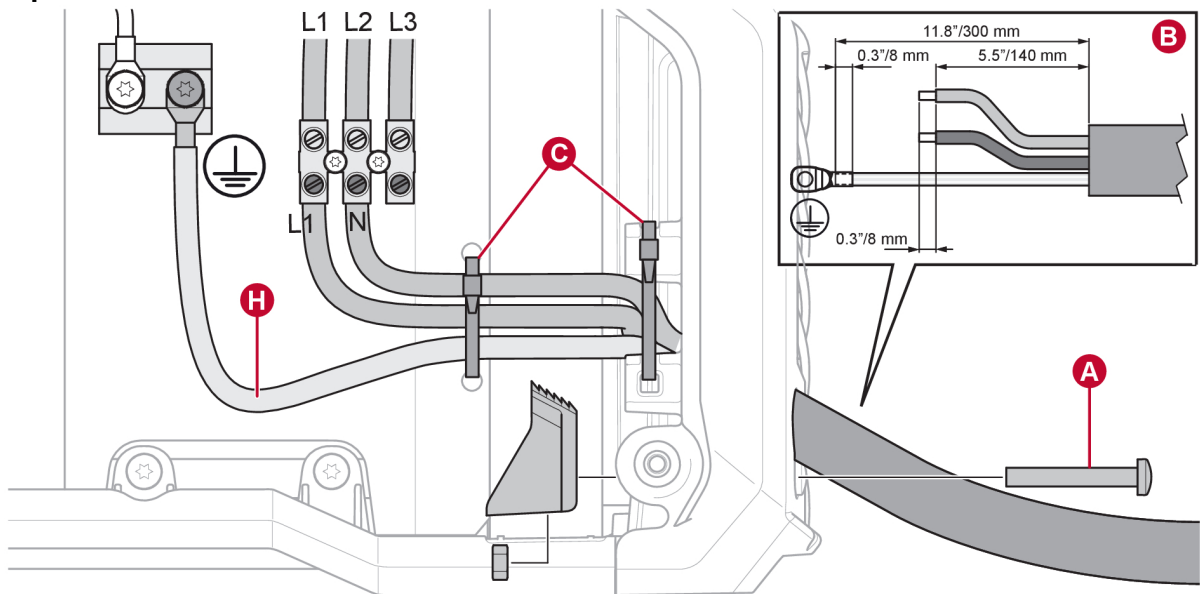

WARNING!

In 1-phase operation the terminal L3 is powered, even though not connected. Make sure to keep terminal L3 disconnected.

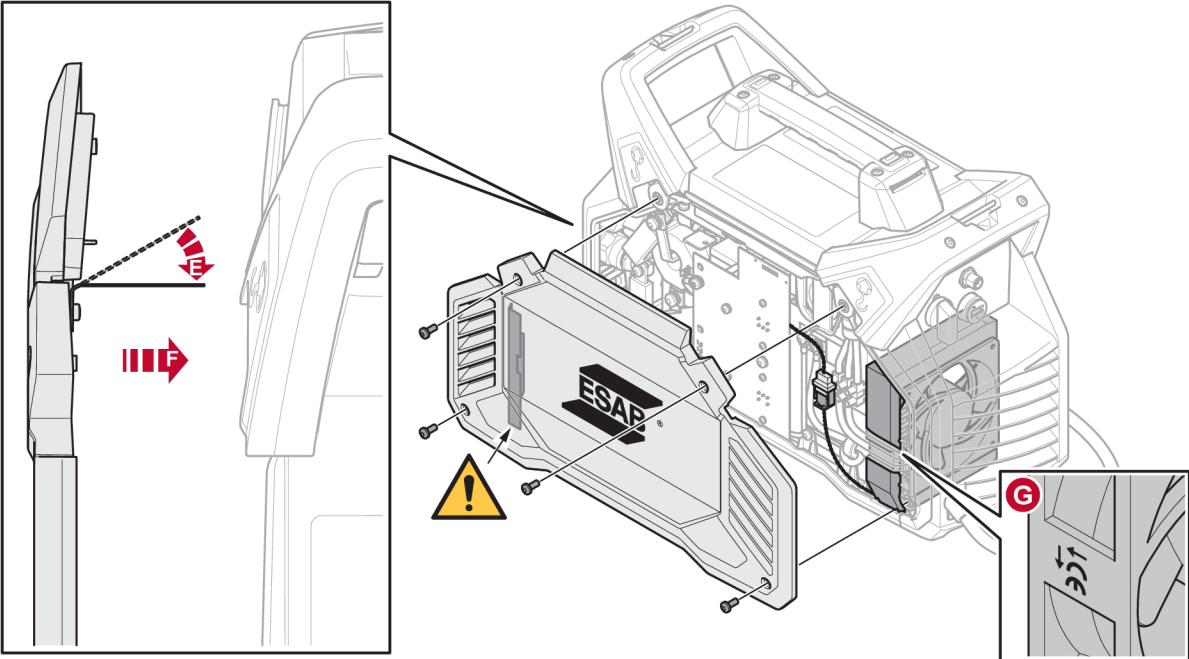

5 OPERATION

5.1 Overview

General safety regulations for handling the equipment can be found in the chapter "Safety." Read it before you start using the equipment.



NOTE!

When moving the equipment, use the handle. Never pull the cables.



WARNING!

Electric shock! Do not touch the workpiece or the welding head during operation!

5.2 Connections and control devices

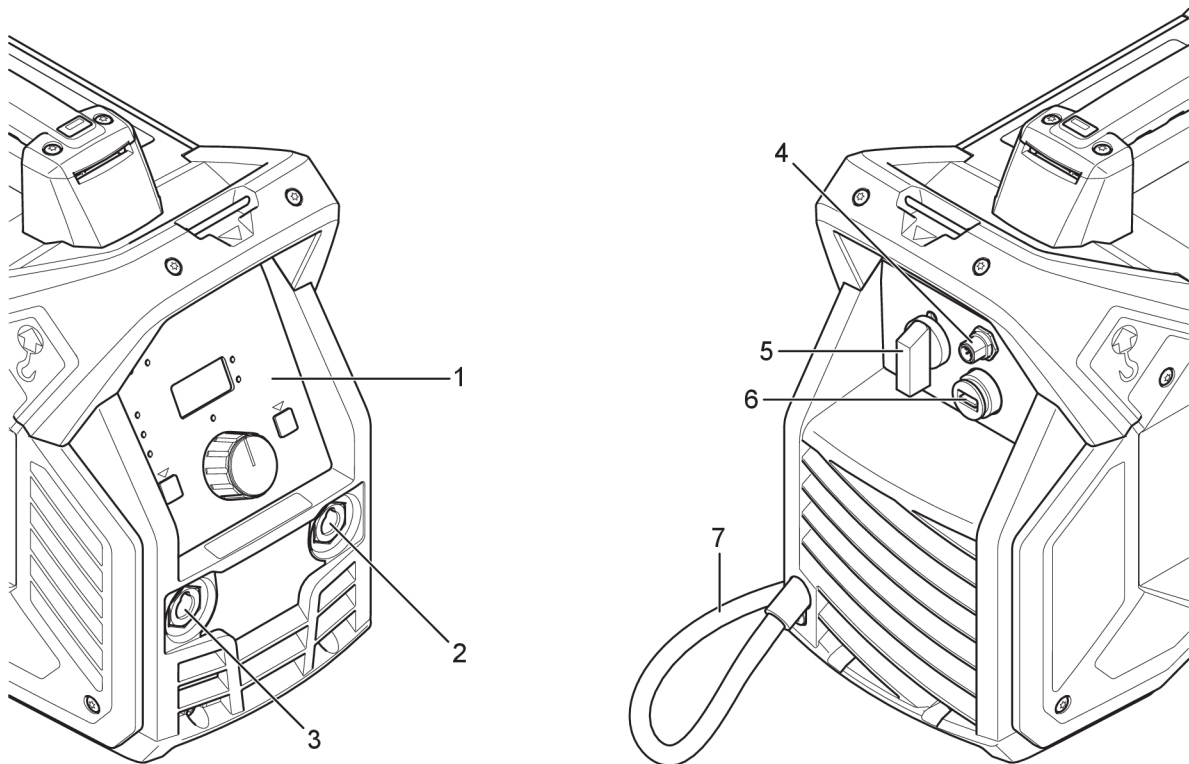

1. Setting panel
2. Positive welding terminal
3. Negative welding terminal
4. Connection for remote control unit

5. Mains power supply switch, I/O
6. USB connection
7. Power cable



NOTE!

Always use the cover when the USB connection is not in use.

5.3 Connecting welding and return cables

The power source has two outputs, a positive welding terminal (+) and a negative welding terminal (-), for connecting welding and return cables. The output to which the welding cable is connected depends on the welding method or type of electrode used.

Connect the return cable to the other output on the power source. Secure the return cable's contact clamp to the workpiece, and make sure that there is a good contact between the workpiece and the output for the return cable on the power source.

- For TIG (GTAW) welding, the negative welding terminal (-) is used for the welding torch and the positive welding terminal (+) is used for the return cable.
- For stick (SMAW) welding, the welding cable can be connected to the positive welding terminal (+) or negative welding terminal (-), depending on the type of electrode used. The connection polarity is stated on the electrode packaging.

5.4 Turning the power on/off

Turn on the power by turning the switch to the "ON" (I) position.

Turn the unit off by turning the switch to the "O" position.

Whether the power supply is interrupted or the power source is switched off in the normal manner, weld programs are stored so that they are available the next time the unit is started.



CAUTION!

Do not turn off the power source during welding (with load).

5.5 Fan control

The power source has automatic thermal control. The fan continues to run for a few minutes after welding has stopped while the power source switches to energy-saving mode. The fan starts again when welding restarts.

In energy-saving mode, the fan starts occasionally and runs for a few minutes.

5.6 Thermal protection



The power source includes thermal protection against overheating. When overheating occurs, welding stops, the overheating indicator on the panel illuminates, and an error message appears on the display screen. The protection is automatically reset once the temperature has decreased to a safe level.

5.7 Functions and symbols



Stick (SMAW) welding

Stick (SMAW) welding can also be referred to as welding with coated electrodes. Striking the arc melts the electrode, and its coating forms protective slag.

For Stick (SMAW) welding, the power source must be supplemented with the following:

- Welding cable with electrode holder
- Return cable with clamp

Soft ↔ Crisp

Soft/Crisp

The arc force function determines how the current changes in response to variations in arc length during welding. Use a low value (Soft) to get a calm arc with little spatter, and use a high value (Crisp) to get a hot and digging arc.

Soft/Crisp only applies to stick (SMAW) welding.

Cel 6010

Cel 6010

Optimized arc characteristics for cellulose electrodes, such as 6010.



TIG (GTAW) welding

TIG welding, also called gas tungsten arc welding (GTAW), melts the metal of the workpiece using an arc struck from a tungsten electrode that does not melt. The weld pool and electrode are protected by shielding gas.

For TIG (GTAW) welding, the welding power source must be supplemented with the following:

- TIG (GTAW) torch with gas valve
- Argon gas cylinder
- Argon gas regulator
- Tungsten electrode

This power source performs **Live TIG (GTAW) start**.

The tungsten electrode is placed against the workpiece. When lifted from workpiece, the arc is struck at a limited current level.

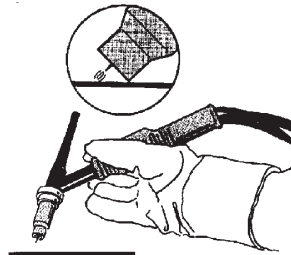
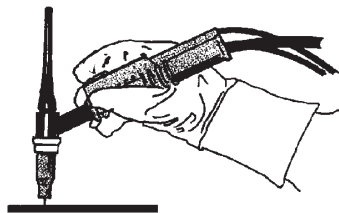

Voltage Reduction Device (VRD)

VRD

The VRD function ensures that the open-circuit voltage does not exceed 35 V when welding is not being carried out. This is indicated by a lit VRD indicator on the panel. Contact an authorized ESAB service technician to activate this function.

5.8 Setting panel

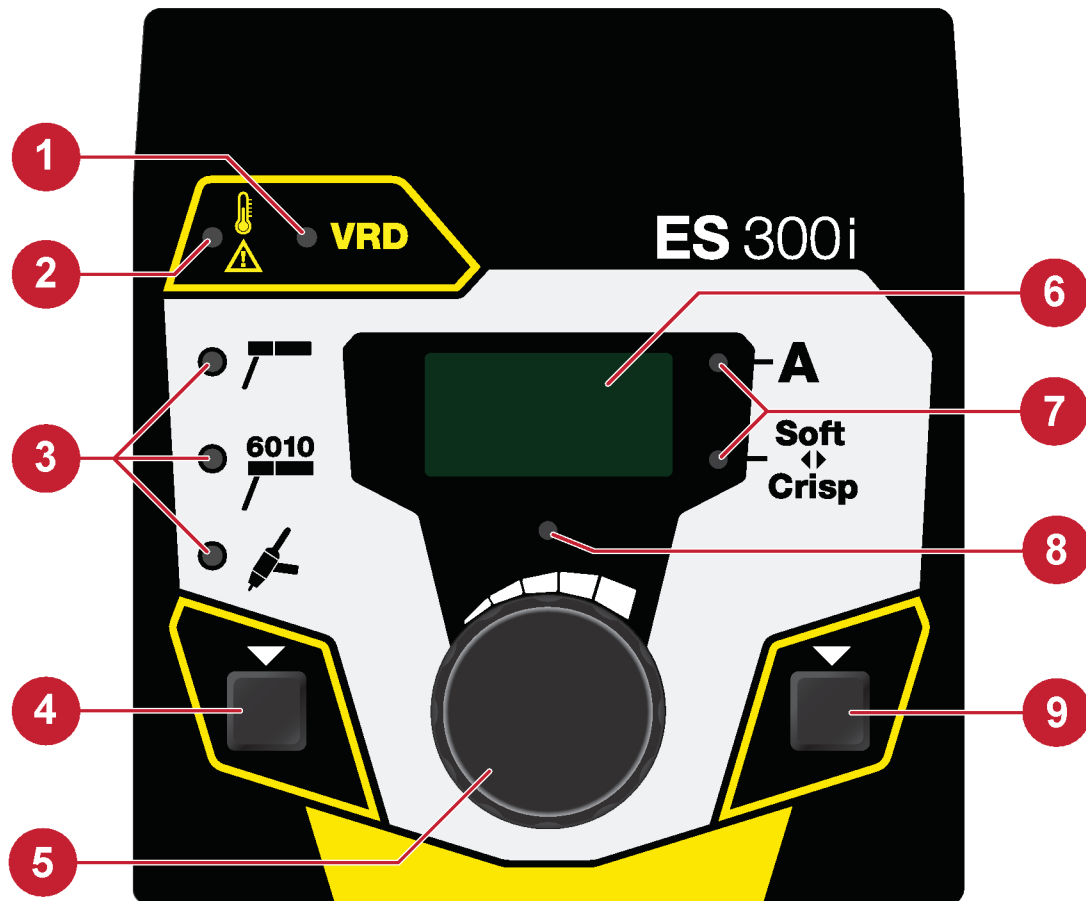

- | | |
|---|---|
| 1. VRD function (reduced open-circuit voltage) indicator. | 6. Display, shows set or measured value. |
| 2. Overheating indication. | 7. Display parameter indicator. |
| 3. Indication of welding method: stick (SMAW) with cellulose electrode or TIG (GTAW). | 8. Set indicator. |
| 4. Select welding method, indicated by (3). | 9. Select parameter to show in display, indicated by (7). |
| 5. Knob for setting data. | |

5.8.1 Navigation

Parameter selection

By pressing the button (9), different values can be shown and changed. Use the knob (5) to change the values. Sequence:

1. Set current values.
2. Measure current values.
3. Soft/Crisp, 0–100%. (only stick (SMAW))

Set parameter

The set indicator (8) illuminates when a value can be changed. It cannot be changed from the panel when a remote is activated. Trying to change a value while in measured value mode results in automatically switching to set current value mode.

5.9 Remote control

Connect the remote control to the rear of the power source. When the remote control is connected, it is automatically activated. The control panel is locked but displays current welding data.

5.10 USB connection



Always use the USB cover when the USB connection is not in use.

Do not use to charge other devices, such as cell phones.

The welding process is blocked when a USB flash drive is connected. The USB connection can be used to retrieve welding statistics. The statistics include total number of welds performed, total welding time and average current.

Retrieving welding statistics

Always make sure that the power source is not being used for welding when retrieving welding statistics.

1. Insert an empty USB flash drive into the power source USB connector.
2. To confirm that the power source has read the USB flash drive, the text "USB" flashes on the display a few times and then is steadily lit.
3. When the text "USB" is shown with fixed light: Remove the USB flash drive from the USB connector.
4. The USB flash drive will contain a text file (.txt) with the welding statistics.
5. The recommended program for opening the text file is Microsoft® WordPad or Microsoft® Word.

5.11 Low energy idle state



Low energy idle state is an energy-saving mode where OCV is zero. OCV will be available based on the user interaction, that is, remote/encoder movement or any button press on the HMI or trigger press.

6 MAINTENANCE



WARNING!

Disconnect power before performing maintenance.



CAUTION!

Only persons with the appropriate electrical knowledge (authorized personnel) may remove safety plates.



CAUTION!

The product is covered by a manufacturer's warranty. Any attempt to carry out repair work by non-authorized service centers will invalidate the warranty.



NOTE!

Regular maintenance is important for safe and reliable operation.



NOTE!





Perform maintenance more often during severe dusty conditions.

Before each use, make sure that the:

- Product and cables are undamaged, and
- The torch is clean and undamaged.

6.1 Routine maintenance

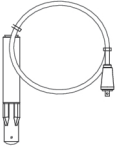
Maintenance schedule during normal conditions. Check equipment before every use.

Interval	Area to maintain		
Every 3 months	 Clean or replace unreadable labels.	 Clean weld terminals.	 Check or replace weld cables.
Every 6 months	 Clean inside equipment. Use dry compressed air with reduced pressure.		

6.2 Cleaning instructions

To maintain the performance and increase the lifetime of the power source, it is mandatory to clean it regularly. How often depends on:

- The welding process,
- The arc time, and
- The working environment.



CAUTION!

The cleaning procedure should be carried out by authorized service technician.



CAUTION!

Make sure that the cleaning procedure is done in a suitable prepared workspace.



CAUTION!

During cleaning, always wear the recommended personal protective equipment, such as earplugs, safety glasses, masks, gloves and safety shoes.

1. Disconnect the power source from the power supply.



WARNING!

Wait at least 30 seconds for the capacitors to discharge before continuing.

2. Remove the four screws holding the right side panel (**R**) and remove the panel.

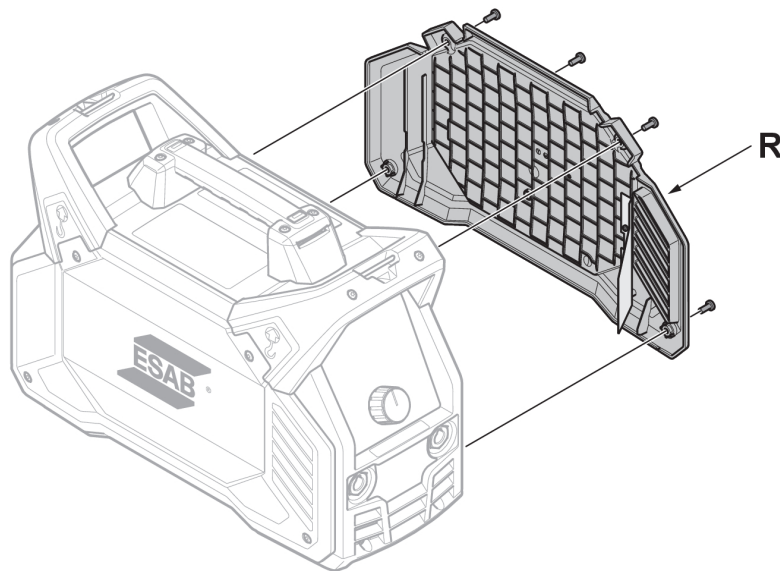

3. Clean the right side of the power source using low-pressure dry compressed air.



NOTE!

Because the power source contains one “dirty” side (the right side) and one “clean” side (the left side), it is important not to remove **the left** side panel before cleaning the right side of the power source.

4. Remove the four screws holding the left side panel (**L**) and remove the panel.

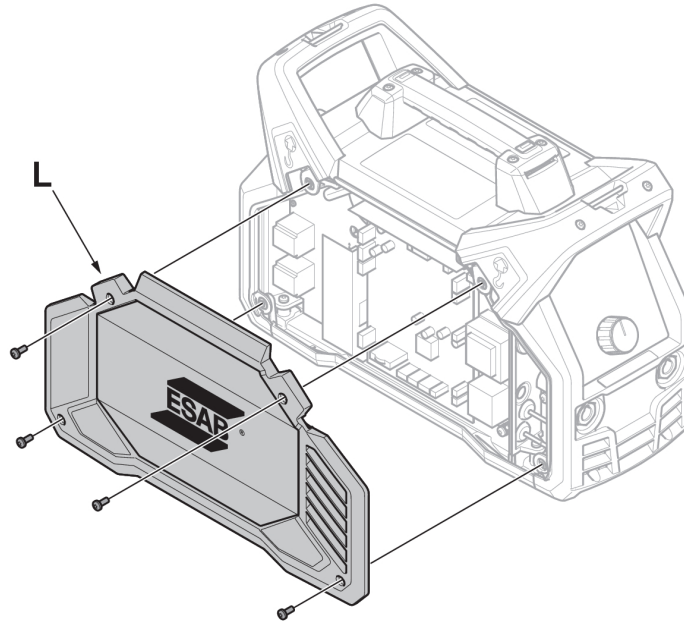

5. Clean the left side of the power source using low-pressure dry compressed air.
6. Make sure that no dust remains on any part of the power source.
7. After cleaning the power source, reattach the power source panels in the reverse order.



NOTE!

When reattaching the right side panel, make sure that the IP shield on the inside of the panel is in the correct position. The IP shield must be angled at about 90° into the power source, so that it is positioned between the welding outlet connector and the transformer outlets.

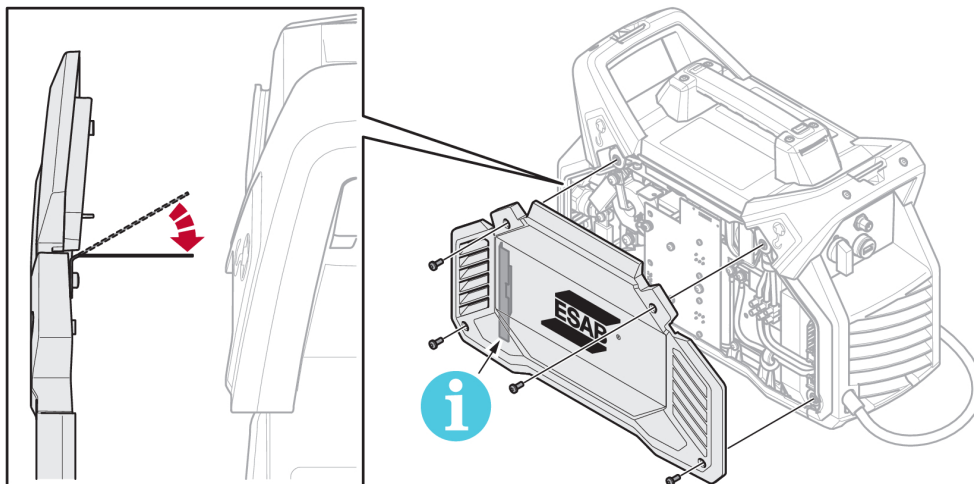

8. Tighten the screws on the side panels with $3 \text{ Nm} \pm 0.3 \text{ Nm}$ ($26.6 \text{ in lb.} \pm 2.6$).

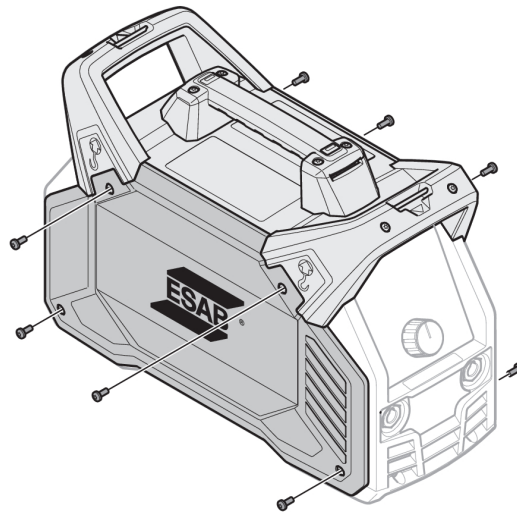

7 TROUBLESHOOTING

Perform these checks and inspections before contacting an authorized service technician.

Type of fault	Corrective action
Stick (SMAW) welding problems	<ul style="list-style-type: none"> • Check that the welding and return cables are correctly connected to the power source. • Make sure that the return clamp has proper contact with the workpiece. • Check that the correct electrodes and polarity are being used. For polarity, check electrode packaging. • Check that the correct current value is set. • Adjust Arc Force and Hot start.
TIG (GTAW) welding problems	<ul style="list-style-type: none"> • Check that the welding and return cables are correctly connected to the power source. • Make sure that the return clamp has proper contact with the workpiece. • Make sure that the TIG torch lead is connected to the negative welding terminal. • Make sure that the correct shielding gas, gas flow, welding current, filler rod placement, electrode diameter and welding mode on power source is used. • Make sure that the gas valve on the TIG torch is on.
No arc	<ul style="list-style-type: none"> • Check that the display is on to verify that the power source has power. • Check that the setting panel is displaying correct values. • Check that the electrical power supply switch is turned on. • Check that the mains, welding, and return cables are correctly connected. • Check the electrical power supply fuses.
Welding current is interrupted during welding	<ul style="list-style-type: none"> • Check whether the overheating light (thermal protection) on the setting panel is on. • Continue with "No Arc."
Thermal protection trips frequently	<ul style="list-style-type: none"> • Make sure that the recommended duty cycle for the weld current has not been exceeded. See the "Duty cycle" section in the TECHNICAL DATA chapter. • Make sure that the air inlets or outlets are not clogged. • Clean the inside of the machine using routine maintenance methods.

8 ERROR CODES

Error codes indicate that a fault has occurred in the equipment. Errors are indicated by the text "Err" followed by the error code number shown in the display.

If more than one error was detected, only the code for the last occurring error is displayed.

8.1 Error code descriptions

Error codes that the user can handle are listed below. If any other error code appears, contact an authorized ESAB service technician.

Error code	Description
Err 1	<p>Temperature fault The temperature of the power source is too high. An LED indicating temperature fault is also illuminated on the panel. A temperature fault is indicated by the overheating indicator on the control panel.</p> <p>Action: The error code will automatically disappear and the LED indicating temperature fault will be turned off when the power source has cooled down and is ready for use again. If the error persists, contact a service technician.</p>
Err 3	<p>Power supply fault The power supply to the power source is too low or too high.</p> <p>One phase is lost during 3-phase operation. Third phase voltage detected during 1-phase operation.</p> <p>Action: Make sure that the power supply is stable, all leads are connected, and the outlet voltage (all three phases) is correct, and then restart the system. If the error persists, contact a service technician.</p>
Err 4	<p>Communication fault The communication in the power source was disrupted.</p> <p>Action: Check cables and connections, restart the power source. If the error persists, contact a service technician.</p>
Err 5	<p>Memory fault The program memory is damaged. This fault can disable preset functions and functions in which values are stored.</p> <p>Action: Remove the error indication from the display by pressing a button on the panel. Restart the power source. If the error persists, contact a service technician.</p>
Err 6	<p>Timing fault The power source electronics are unable to execute all functions in a timely fashion.</p> <p>Action: Restart the power source. If the error persists, contact a service technician.</p>
Err 7	<p>OCV fault The OCV is too high, or the electronic control of the OCV was disrupted.</p> <p>Action: Restart the power source. If the error persists, contact a service technician.</p>

9 ORDERING SPARE PARTS

Repair and electrical work should be performed by an authorized ESAB service technician. Use only ESAB original spare and wear parts.

The ES 300i is designed and tested in accordance with international standards **CAN/CSA E60974-1** and **ANSI/IEC 60974-1**. On completion of service or repair work, it is the responsibility of the person(s) performing the work to ensure that the product still complies with the requirements of the above standards.

Spare parts and wear parts can be ordered through your nearest ESAB dealer, see the back cover of this document. When ordering, please state product type, serial number, designation and spare part number in accordance with the spare parts list. This facilitates dispatch and ensures correct delivery.

DIAGRAM

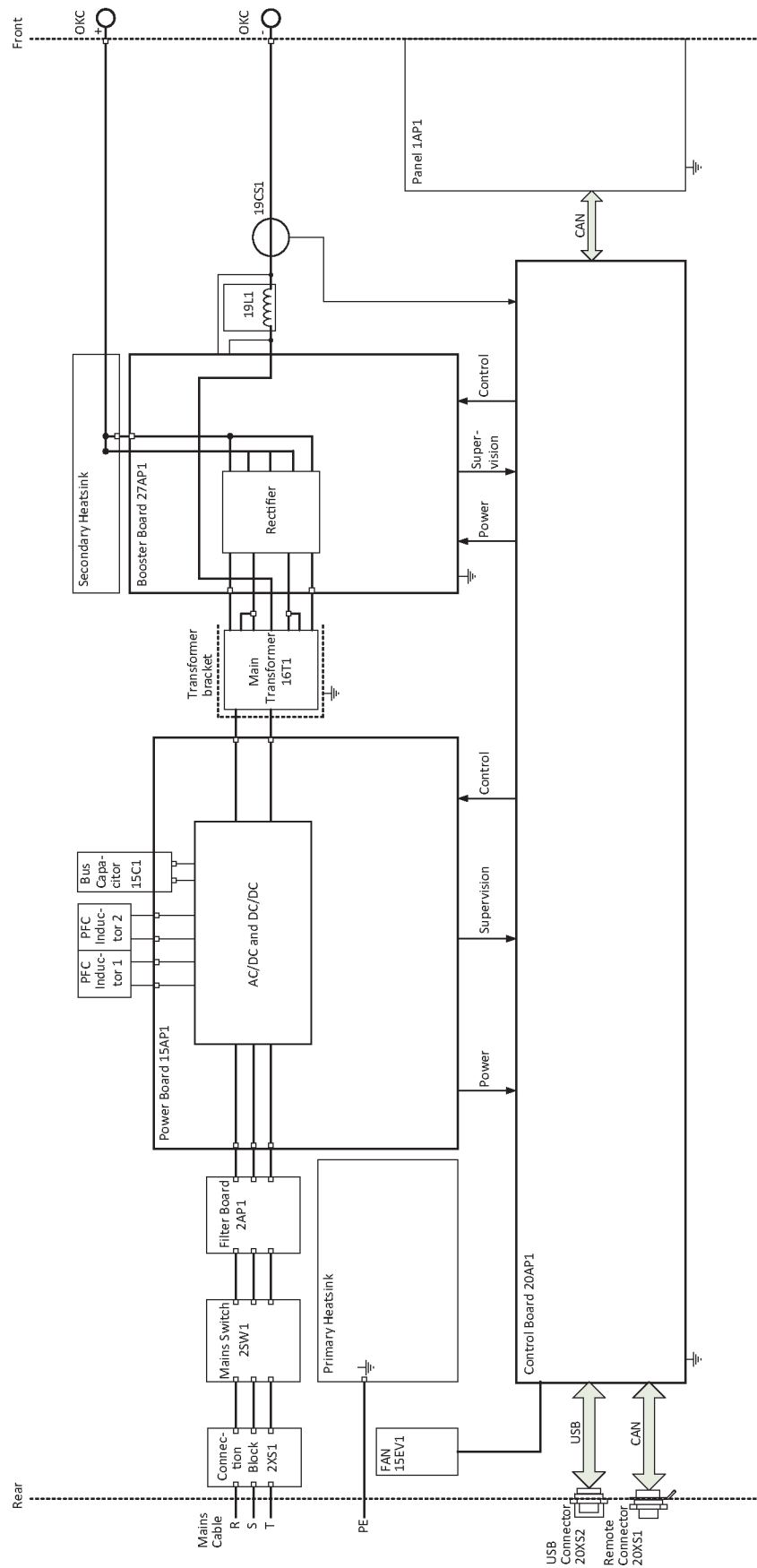

ORDERING NUMBERS

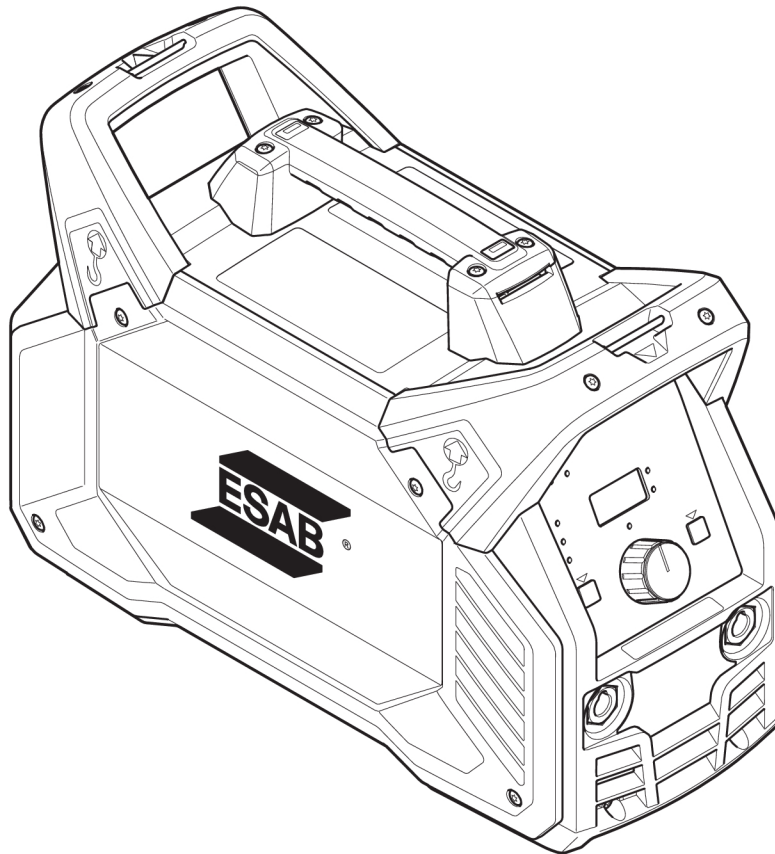

Ordering number	Denomination	Type	Notes
0445 100 881	Welding power source	ES 300i	North America
0445 100 882	Welding power source	ES 300i	South America
0463 417 *	Instruction manual		
0463 423 001	Spare parts list		

The three last digits in the document number of the manual show the version of the manual. Therefore they are replaced with * here. Make sure to use a manual with a serial number or software version that corresponds with the product, see the front page of the manual.

Technical documentation is available on the Internet at: www.esab.com

ACCESSORIES

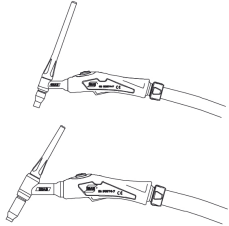
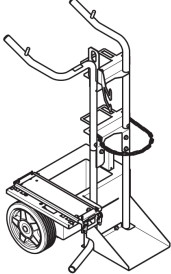
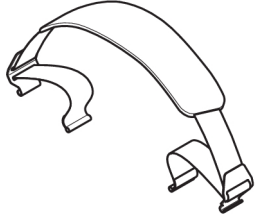
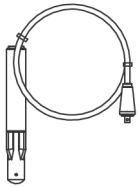
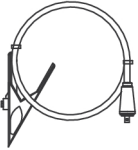
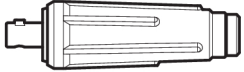
<p>TIG torches</p> <p>0700 300 539</p> <p>0700 300 545</p> <p>0700 300 553</p> <p>0700 300 556</p>	<p>TXH™ 151 V, OKC 50, 4 m</p> <p>TXH™ 151 V, OKC 50, 8 m</p> <p>TXH™ 201 V, OKC 50, 4 m</p> <p>TXH™ 201 V, OKC 50, 8 m</p>	
<p>0460 330 881</p>	<p>Trolley</p>	
<p>0445 197 880</p>	<p>Shoulder strap kit</p>	
<p>0700 006 902</p>	<p>Welding cable kit 3 meter, incl. electrode holder and OKC 50 connector</p>	
<p>0700 006 888</p>	<p>Welding cable kit 5 meter, incl. electrode holder and OKC 50 connector</p>	
<p>0700 006 903</p>	<p>Return cable kit 3 meter, incl. clamp and OKC 50 connector</p>	
<p>0700 006 889</p>	<p>Return cable kit 5 meter, incl. clamp and OKC 50 connector</p>	
<p>0160 360 881</p>	<p>OKC 50 male contact</p>	

ACCESSORIES

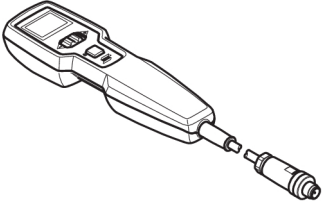
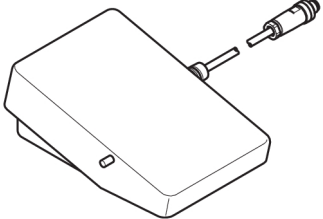
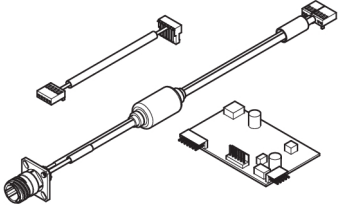
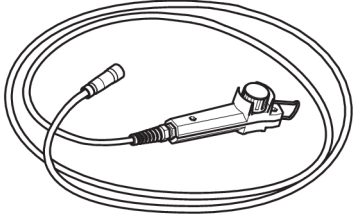
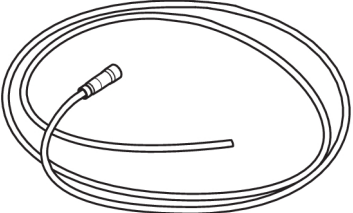
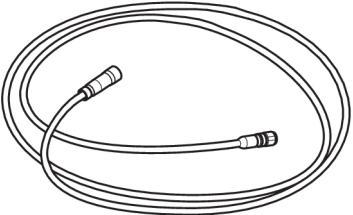
0445 536 881	ER 1 Remote control. 16.4 ft (5 m) interconnection cable, 6 pin, included.	
0445 536 882	ER 1 Remote control. 10 m (32.8 ft) interconnection cable, 6 pin, included.	
0445 536 883	ER 1 Remote control. 25 m (82 ft) interconnection cable, 6 pin, included.	
0445 280 880	Interconnection cable, 6 pin, 16.4 ft (5 m)	
0445 280 881	Interconnection cable, 6 pin, 32.8 ft (10 m)	
0445 280 882	Interconnection cable, 6 pin, 82 ft (25 m)	
0445 550 881	ER 1 F Foot pedal 16.4 ft (5 m) interconnection cable, 6 pin, included	
0445 254 880	Interconnection cable, 6 pin, 16.4 ft (5 m)	
0445 254 881	Interconnection cable, 6 pin, 32.8 ft (10 m)	
0445 840 880	Renegade analogue remote kit	
0445 870 880	Remote Control MMA3, 10 m	
0445 870 881	Remote Control MMA3, 25 m	
0445 693 880	Interconnection cable for analogue remote control MMA3, 10 m	
0445 693 881	Interconnection cable for analogue remote control MMA3, 25 m	
0445 694 880	Interconnection cable for analogue remote controls AT1 and AT1 C/F, 10 m	
0445 694 881	Interconnection cable for analogue remote controls AT1 and AT1 C/F, 25 m	



A WORLD OF PRODUCTS AND SOLUTIONS.



For contact information visit esab.com

ESAB AB, Lindholmsallén 9, Box 8004, 402 77 Gothenburg, Sweden, Phone +46 (0) 31 50 90 00

manuals.esab.com

